

OPLS™

by WASH

ON-PREMISE LAUNDRY SOLUTIONS

Softmount Washer-Extractor

PYN230

230 lb (104 kg)

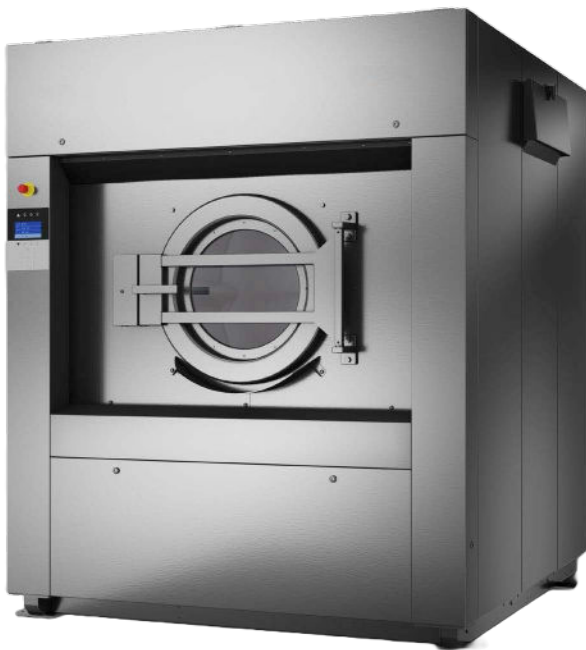

FEATURES

- Freestanding, high speed spin up to 350G
- Patented Cascade Drum™
- Stainless steel top, front and side panels
- Stainless steel drum and tub
- Easy Soap™ - liquid soaps connection
- Large door opening for easy loading/unloading
- Large dual drain valves
- Ergonomic height of door enables easy access
- Soap hopper

XCONTROL+

- Fully programmable
- 20 preset programs, up to 99 in memory



ERGONOMIC
CONSTRUCTION



LARGE DOOR
OPENING



LOW WATER
AND ENERGY
CONSUMPTION



WASH
COMMERCIAL LAUNDRY

800-236-5599 | www.wash.com/on-premise

Softmount Washer-Extractor

Specifications

			PYN230
CONTROL OPTION			XControl+
CAPACITY - lb (kg)			230 (104)
DIMENSIONS W/ TILT - in (mm)		Width	75.59 (1920)
		Depth	80.98 (2057)
		Height	86.30 (2192)
NET WEIGHT W/ TILT - lb (kg)			7760 (3520)
CYLINDER DIAMETER - in (mm)			47.24 (1200)
CYLINDER DEPTH - in (mm)			33.85 (860)
CYLINDER VOLUME - cu. ft. (liters)			35.4 (1003)
DOOR OPENING SIZE - in (mm)			20.86 (530)
DOOR BOTTOM TO FLOOR - in (mm)			33.74 (857)
WASH SPEED - RPM			33
EXTRACT SPEED - RPM			720
EXTRACT G-FORCE			350
WATER INLET CONNECTION - in (mm)			3 x 1.5 (38)
STEAM INLET CONNECTION - in (mm)			1 (25)
DRAIN CONNECTION - in (mm)			2 x 4 (102)
MOTOR POWER CONSUMPTION - hp (kw)			20.12 (15)
VOLTAGE/CIRCUIT BREAKER - FLA		208-240/60/3	50-35
		400-480/60/3	40-25.2
SHIPPING DIMENSIONS		Width	81.89 (2080)
APPROX. W/ TILT - in (mm)		Depth	92.52 (2350)
		Height	95.47 (2425)
SHIPPING WEIGHT W/ TILT - lb (kg)			7981 (3620)
AGENCY APPROVALS			CSA

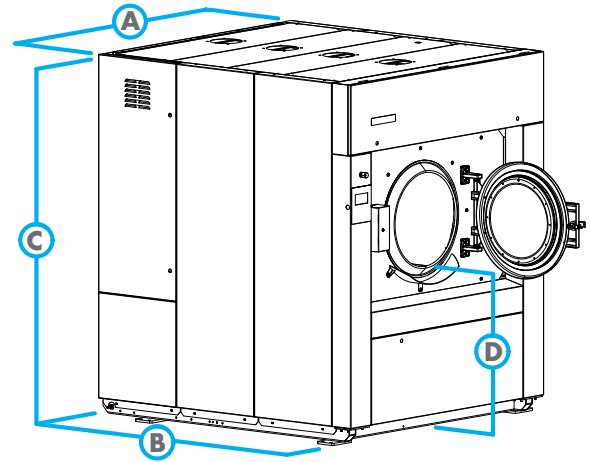

A. OVERALL WIDTH - in (mm)	75.59 (1920)
B. OVERALL DEPTH - in (mm)	80.98 (2057)
C. OVERALL HEIGHT - in (mm)	86.30 (2192)
D. DOOR BOTTOM TO FLOOR - in (mm)	33.74 (857)

used for all design and construction purposes. Due to continuous product improvements, design and specifications subject to change without notice. The quality management systems at Alliance Laundry Systems are registered to ISO 9001.

April 2026 Specification

OPLS by WASH is manufactured by Alliance Laundry Systems LLC



800-236-5599 | www.wash.com/on-premise