

# OPLS™

by WASH

ON-PREMISE LAUNDRY SOLUTIONS

## Hardmount Washer-Extractor

PAN030

30 lb (14 kg)



### FEATURES

- High speed spin up to 200G
- Patented Cascade Drum™
- Stainless steel top, front and side panels
- Stainless steel drum and tub
- Easy Soap™ - liquid soaps connection
- Large door opening for easy loading/unloading
- Soap hopper

### XCONTROL+

- Fully programmable
- 20 preset programs, up to 99 in memory



ERGONOMIC  
CONSTRUCTION



LARGE DOOR  
OPENING



LOW WATER  
AND ENERGY  
CONSUMPTION

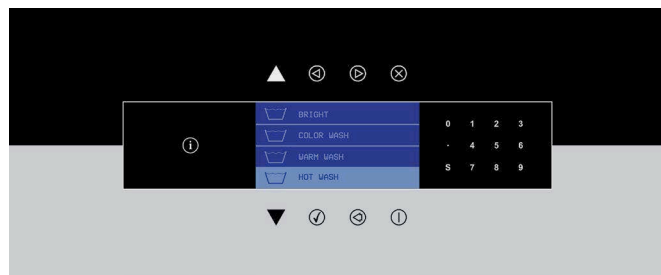

# WASH

*Ideas for the future. Answers for today.®*

1.877.836.5599 | [www.wash.com/on-premise](http://www.wash.com/on-premise)

# Hardmount Washer-Extractor

## Specifications

| PAN030                                     |              |
|--|--------------|
| CONTROL OPTION                             | XControl+    |
| CAPACITY - lb (kg)                         | 30 (14)      |
| OVERALL WIDTH - in (mm)                    | 29.53 (750)  |
| OVERALL DEPTH - in (mm)                    | 35.43 (900)  |
| OVERALL HEIGHT - in (mm)                   | 48.22 (1225) |
| CYLINDER DIAMETER - in (mm)                | 24.4 (620)   |
| CYLINDER VOLUME - cu. ft. (liters)         | 4.8 (136)    |
| DOOR OPENING SIZE - in (mm)                | 16.14 (410)  |
| DOOR BOTTOM TO FLOOR - in (mm)             | 13.46 (342)  |
| WASH SPEED - RPM                           | 46           |
| EXTRACT SPEED - RPM                        | 760          |
| EXTRACT G-FORCE                            | 200          |
| STEAM HEATING - psi                        | 15-116       |
| SOUND PRESSURE LEVEL - dB (A)              | < 65         |
| WATER VALVE CONNECTION - NPT*              | 0.75"        |
| WATER PRESSURE -psi                        | 15-116       |
| RECOMMENDED WATER PRESSURE - psi           | 44-73        |
| WATER INLET (EACH) - g/min                 | 5.28         |
| DRAIN VALVE - in (mm)                      | 3 (76)       |
| FLOW AMOUNT W/ DRAIN VALVE - g/min         | 55.48        |
| FLOOR TO DRAIN OUTLET CENTER - in (mm)     | 3.95 (100)   |
| SIDE TO DRAIN OUTLET CENTER - in (mm)      | 8.85 (225)   |
| STEAM VALVE CONNECTION - BSP               | 0.5"         |
| VOLTAGE/CIRCUIT BREAKER - FLA 208-240/60/1 | 10-7.2       |
| SHIPPING DIMENSIONS APPROX. - in (mm)      |              |
| Width                                      | 31.5 (800)   |
| Depth                                      | 37.4 (950)   |
| Height                                     | 53.35 (1355) |
| NET WEIGHT - lb (kg)                       | 419 (190)    |
| SHIPPING WEIGHT - lb (kg)                  | 441 (200)    |
| AGENCY APPROVALS                           | CSA          |

\*Fill hoses provided to convert BSP at machine to NPT supply connection.

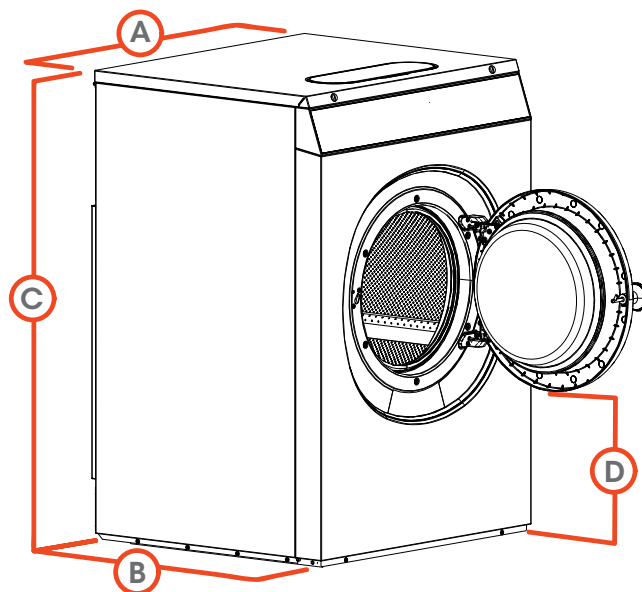

|    |                                |              |
|----|--------------------------------|--------------|
| A. | Overall Width - in (mm)        | 29.53 (750)  |
| B. | Overall Depth - in (mm)        | 35.43 (900)  |
| C. | Overall Height - in (mm)       | 48.22 (1225) |
| D. | Door Bottom to Floor - in (mm) | 13.46 (342)  |

For the most accurate information, the installation guide should be used for all design and construction purposes. Due to continuous product improvements, design and specifications subject to change without notice. The quality management systems at Alliance Laundry Systems are registered to ISO 9001. 2023 Specifications

OPLS by WASH is manufactured by Alliance Laundry Systems LLC



*Ideas for the future. Answers for today.®*

1.877.836.5599 | [www.wash.com/on-premise](http://www.wash.com/on-premise)