

# LG COMMERCIAL LAUNDRY FRONT LOAD WASHER

- Professional Grade Durability
- Best in Class performance
- Comprehensive 3year Warranty



## PREMIUM POWDER COATING

Our powder coated finish creates the same durability as it does when painting a car. It is sure to last long and provide an easy to clean exterior.



## ATOMIZING & TWIN SPRAY

Twin Spray rinses your clothes non-stop while spinning, resulting in a speedier wash and higher customer rotation rate. Atomizing Spray also sprays water on the door, so you don't have to clean excess suds off the door glass.



## INVERTER DIRECT DRIVE™

Unlike the traditional belt and pulley system, the LG commercial laundry drum is directly attached to the motor providing superior durability and reliability. Fewer parts equals fewer repairs.



## 10° TILTED DRUM

LG's commercial washer tub is tilted 10°. It enables the washer to have higher water level compared to competitors. This allows us to use less water while not sacrificing superior wash performance.



## GYRO BALANCING SYSTEM

LG's Gyro Balancing Sensor precisely detects the tub movement to activate the most proper algorithm for washing cycle, ensuring it finishes within 36 mins.



## AUTO DOSING SYSTEM

Simple to connect automatic detergent/chemical injection system.  
\*Autodosing Pump (Purchase Separately)



# GIANT MAX WASHER SPECIFICATIONS

MODEL		GCWM1069***
<b>CYLINDER</b>		
Drum Volume	cu.ft (ℓ)	Giant-C Max : 3.7 (102.7)
Diameter	in. (mm)	22.1 (560)
Depth	in. (mm)	16.5 (419.3)
<b>DIMENSIONS</b>		
Product (WxHxD)	in	27 x 38.7 x 30.2
	mm	686 x 983 x 767
With Door Open	in. (mm)	50.8 (1,291)
Carton (WxHxD)	in	29.7 x 44.4 x 31.3
	mm	755 x 1,127 x 795
Weight (Product/Carton)	lb (kg)	191(87) / 211(96)
<b>SPEED</b>		
Wash	RPM	40-50
Extract (High Speed)	RPM	1,200
G-force	G	451
<b>RATING</b>		
Electric Ratings		120/60/5
<b>*CONSUMPTION INDEX<sup>1)</sup></b>		
Water	gal (ℓ)	13.2 (50)
Electricity	kW/hour	0.5
<b>NOISE &amp; CYCLE TIME</b>		
Noise Level (Sound Power)	dB	Lower than 62
Program Duration in Minutes (Default)	min	36
<b>SYSTEM &amp; CONTROL</b>		
Inverter Direct Drive Motor		0
Heating Element	W	-
Drain System		Pump drain
<b>PROGRAMS</b>		
Program List		Hot
		Warm
		Cold
		Delicates
		Add Super Wash (Card & Coin)/ Custom PGM (OPL)
<b>EXTERNAL FINISH</b>		
Drum		Stainless Steel
<b>CIRCUIT PROTECTION</b>		
PCB Fuse - Main Control Board	amps	12 (220-240V)
PCB Fuse - Filter Assembly	amps	15

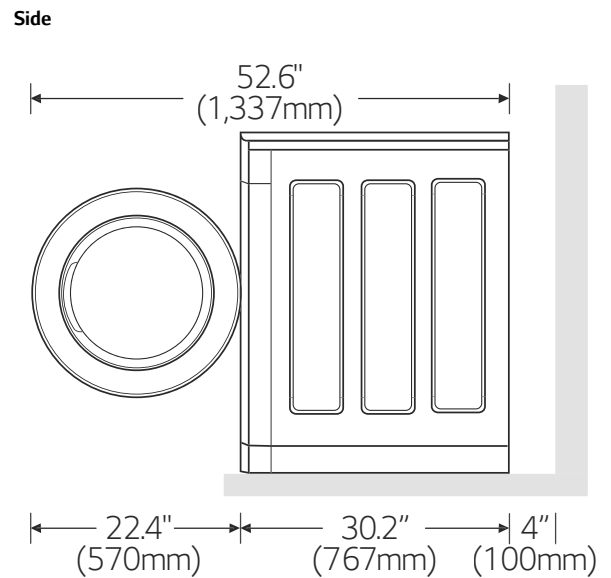
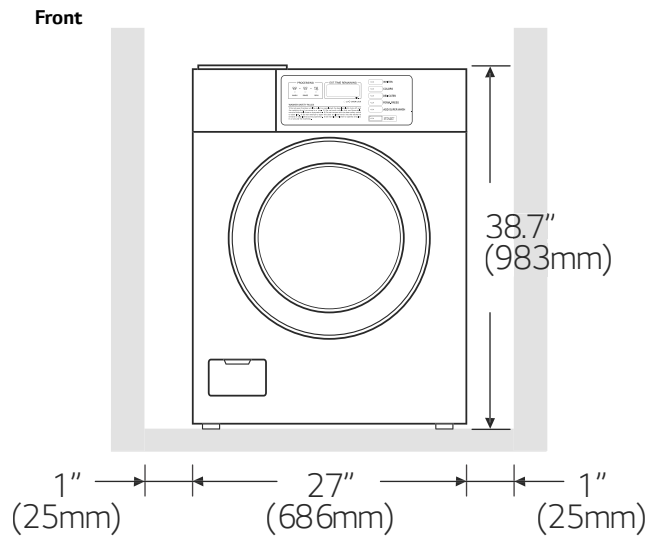

## PRODUCT IMAGE



Coin Convertible

Card / OPL Type

Stack Type (Coin, Card/OPL)