

ON-PREMISES SOFTMOUNT WASHER EXTRACTOR

OPLS[™]
by *WASH*

PYN40

40lb

PYN
RANGE



FEATURES

- Freestanding, high spin, 400 G-Force
- Stainless steel top, front, and side panels
- Stainless steel cylinder and tub
- Patented Cascade™ cylinder for better washability
- XControl+ – fully programmable control
- Patented soap hopper
- High water inlets
- Large drain valve
- Front access to vital parts for easy maintenance
- USB plug on the back panel and control board
- Warranty: First three years on all parts; First five years frame and cylinder shaft assembly; First five years on cylinder bearings and bearing seals (parts only)

OPTIONS

- Third water inlet
- Steam heating

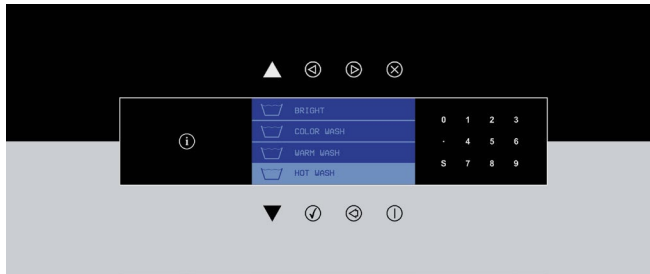

ERGONOMICAL
CONSTRUCTION



LARGE DOOR
OPENING



LOW WATER
AND ENERGY
CONSUMPTION



3 YEAR PARTS
WARRANTY

WASH

800-236-5599 | www.wash.com/on-premise

MODEL		PYN40
CONTROL OPTION		XControl+
CAPACITY - lb (kg)		40 (18)
OVERALL WIDTH - in (mm)		38.18 (970)
OVERALL DEPTH - in (mm)		38.18 (970)
OVERALL HEIGHT - in (mm)		55.51 (1410)
CYLINDER DIAMETER - in (mm)		29.53 (750)
CYLINDER DEPTH - in (mm)		16.14 (410)
CYLINDER VOLUME - cu. ft (liters)		6.4 (180)
DOOR OPENING SIZE - in (mm)		18.11 (460)
DOOR BOTTOM TO FLOOR - in (mm)		18.77 (477)
WASH SPEED - RPM		42
EXTRACT SPEED - RPM		980
EXTRACT G-FORCE		400
WATER INLET CONNECTION - in (mm)		2 x 0.75 (19)
STEAM INLET CONNECTION - in (mm)		0.5 (13)
DRAIN CONNECTION - in (mm)		3 (76)
FLOOR TO DRAIN OUTLET CENTER - in (mm)		5.21 (132)
SIDE TO DRAIN OUTLET CENTER - in (mm)		10.62 (270)
MOTOR POWER CONSUMPTION - hp (kw)		2.95 (2.20)
VOLTAGE/CIRCUIT BREAKER - FLA		208-240/60/1 440-480/60/3
SHIPPING DIMENSIONS APPROX. - in (mm)		Width Depth Height
		40.35 (1025) 39.96 (1015) 61.02 (1550)
NET WEIGHT - lb (kg)		838 (380)
SHIPPING WEIGHT - lb (kg)		871 (395)
AGENCY APPROVALS		cCSAus

DIMENSIONS		PYN40
A. OVERALL WIDTH - in (mm)		38.18 (970)
B. OVERALL DEPTH - in (mm)		38.18 (970)
C. OVERALL HEIGHT - in (mm)		55.51 (1410)
D. DOOR BOTTOM TO FLOOR - in (mm)		18.77 (477)

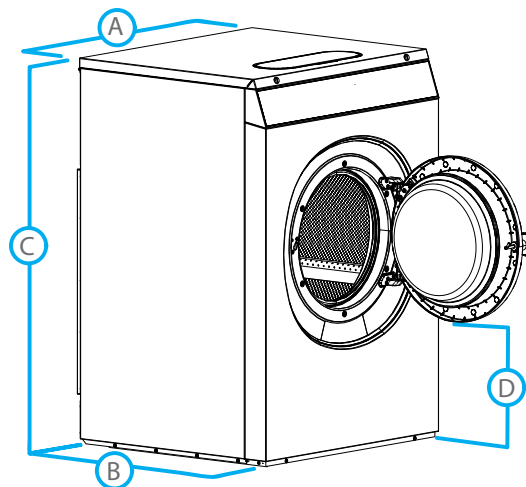

WASH

800-236-5599 | www.wash.com/on-premise