

ON-PREMISES PREMIUM SINGLE TUMBLE DRYER

OPLS™ by WASH

PT
RANGE

PT120

120lb



FEATURES

- Easy-to-use digital control
- Electric, gas and steam heating
- Large door opening for easy loading and unloading
- Galvanized cylinder
- Radial airflow
- Standard reversing cylinder to avoid tangling of large items
- Large self-cleaning lint screen
- Preheating of intake air

OPTIONS

- Stainless steel cylinder
- Stainless steel front panel
- Sensodry+® over-dry prevention technology lowers energy, utility and linen replacement costs
- SafeTech™ Fire Suppression System, a multi-port water manifold system, will saturate linens in an unlikely event of fire within the cylinder



FAST DRYING



EASY OPERATION



SERVICE FRIENDLY



XQ Control



Dual Digital Control

WASH

800-236-5599 | www.wash.com/on-premise

MODEL		PT120
CONTROL OPTION		XQ, DDC
CAPACITY - lb (kg)		120 (54)
OVERALL WIDTH - in (mm)		46.38 (1178)
OVERALL DEPTH - in (mm)		67.92 (1725)
OVERALL HEIGHT - in (mm)	Gas/Electric	85.7 (2177)
	Steam	83.5 (2121)
CYLINDER DIAMETER - in (mm)		44 (1118)
CYLINDER VOLUME - cu. ft (liters)		36.1 (1022)
DOOR OPENING SIZE - in (mm)		26.88 (683)
ENERGY DATA	Steam Models - 100 psi	405,000 Btu/h
	Electric Models	60 kW
	Gas Models	270,000 Btu/h
EXHAUST - in (mm)		10 (254)
GAS CONNECTIONS - one manifold - in (npt)		1
STEAM CONNECTIONS - in (npt)		0.75
MOTOR - hp	Fan	1
	Drive	0.75
DRYING AVERAGE - lbs/min	Gas Heating	1.94
	Electric Heating	1.77
AIRFLOW - cfm		1600
ELECTRIC SPECS - amps		Rev
GAS & STEAM	200-208/240/60/3 3W+G	7.7
	380/60/3 3W+G	4.1
	*Steam Only - 440/60/3 3W+G	3.8
	460-480/60/3 3W+G	3.9
ELECTRIC	240/60/3 3W+G	152
	380/60/3 3W+G	94.5
	480/60/3 3W+G	76.1
SHIPPING DIMENSIONS APPROX.	Width	48.5 (1232)
	Depth	71.5 (1816)
	Height	90 (2286)
NET WEIGHT - lb (kg)	Gas/Electric	1275 (578)
	Steam	1375 (624)
SHIPPING WEIGHT - lb (kg)	Gas/Electric	1338 (607)
	Steam	1446 (656)
AGENCY APPROVALS		cCSAus

*The data concerning dimensions of machines includes all extended parts.

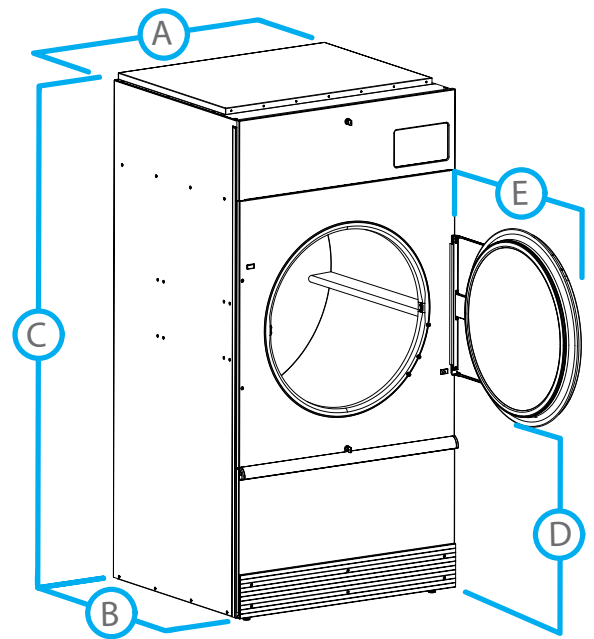

DIMENSIONS		PT120
A.	OVERALL WIDTH - in (mm)	46.38 (1178)
B.	OVERALL DEPTH - in (mm)	67.92 (1725)
C.	OVERALL HEIGHT - in (mm)	Gas/Electric 85.7 (2177)
		Steam 83.5 (2121)
D.	DOOR BOTTOM TO FLOOR - in (mm)	31.38 (797)
E.	DOOR SWING - in (mm)	32.5 (826)

WASH

800-236-5599 | www.wash.com/on-premise